

**UNIT IV**  
**CROSSED FILED TUBES & MICROWAVE SEMICONDUCTOR**  
**DEVICES**

**MAGNETRON :**

The magnetron encompasses a class of devices finding a wide variety of applications. Pulsed magnetrons have been developed that cover frequency ranges from the low UHF band to 100 GHz. Peak power from a few kilowatts to several megawatts has been obtained. Typical overall efficiencies of 30 to 40 percent may be realized, depending on the power level and operating frequency. CW magnetrons also have been developed, with power levels of a few hundred watts in a tunable tube, and up to 25kW or more in a fixed-frequency device. Efficiencies range from 30 percent to as much as 70 percent. The magnetron operates electrically as a simple diode. Pulsed modulation is obtained by applying a negative rectangular voltage waveform to the cathode with the anode at ground potential. Operating voltages are less critical than for beam tubes line-type modulators often are used to supply pulsed electric power. The physical structure of a conventional magnetron is shown in Figure.

High-power pulsed magnetrons are used primarily in radar systems. Low-power pulsed devices find applications as beacons. Tunable CW magnetrons are used in ECM (electronic countermeasures) applications. Fixed-frequency devices are used as microwave heating sources

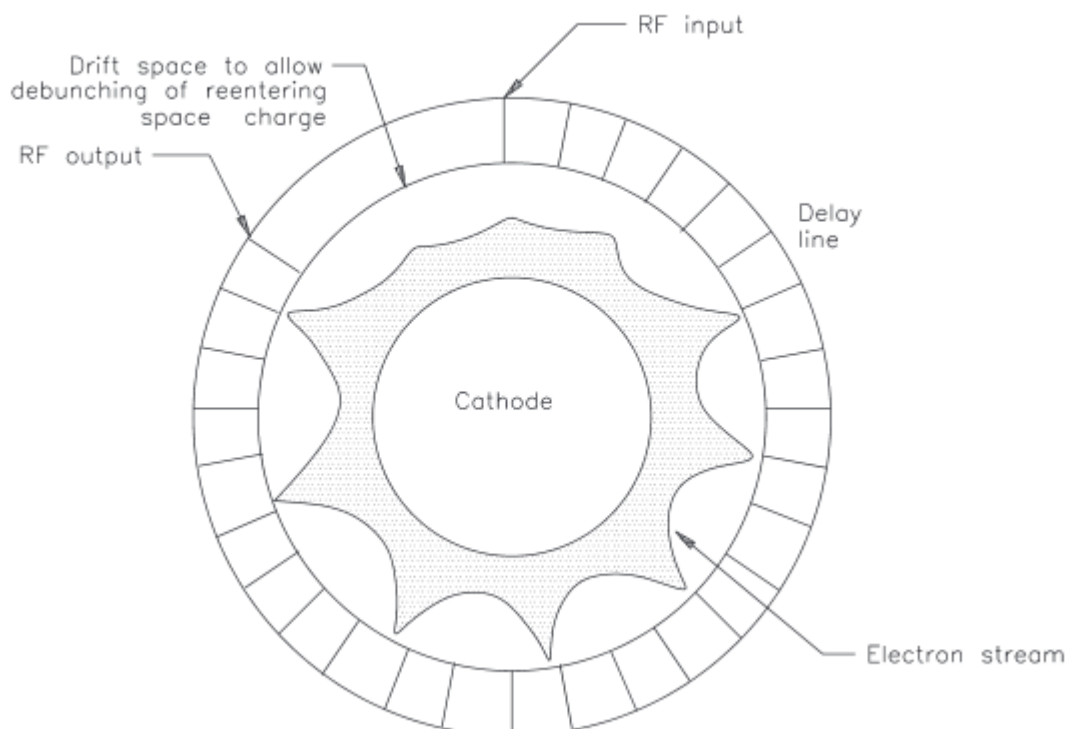
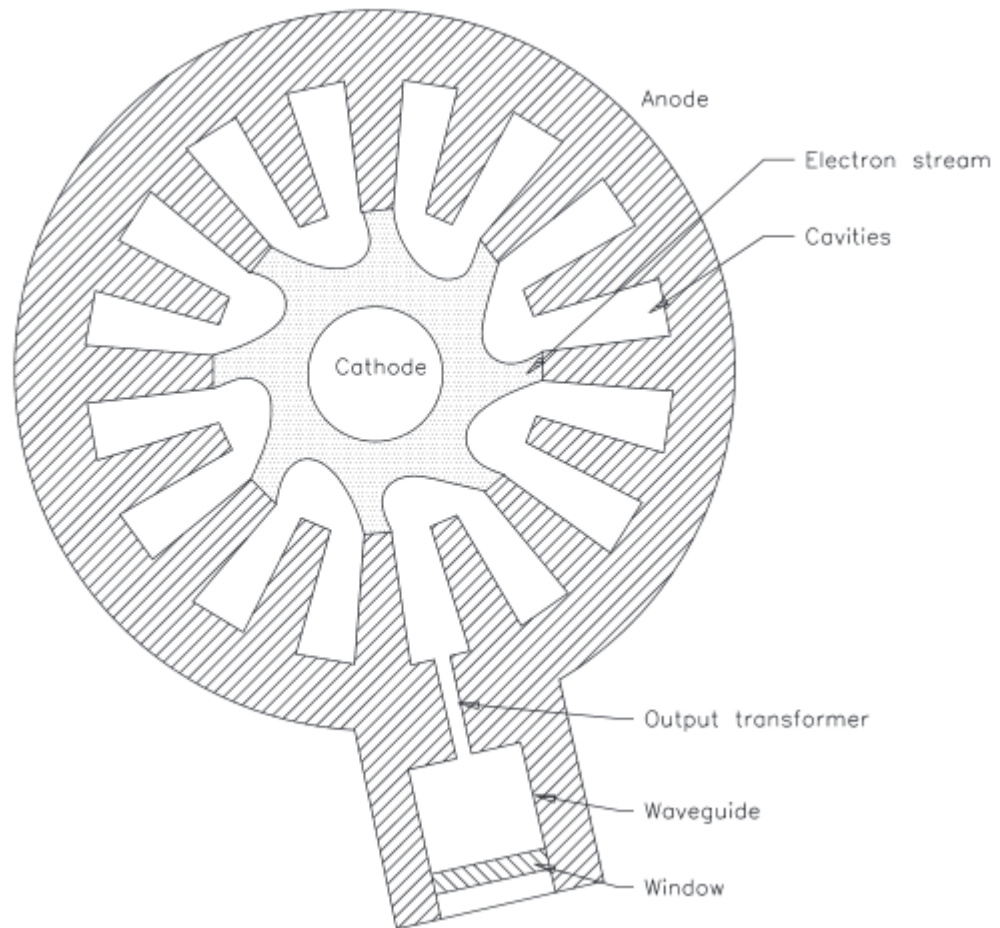

**Figure :Reentrant emitting-sole crossed-field amplifier tube.**

Tuning of conventional magnetrons is accomplished by moving capacitive tuners or by inserting symmetrical arrays of plungers into the inductive portions of the device. Tuner motion is produced by a mechanical connection through flexible bellows in the vacuum wall. Tuning ranges of 10 to 12 percent of bandwidth are possible for pulsed tubes, and as much as 20 percent for CW tubes.

### **Operating Principles**

Most magnetrons are built around a cavity structure of the type shown in Figure. The device consists of a cylindrical cathode and anode, with cavities in the anode that open into the cathode-anode space—the interaction space as shown. Power can be coupled out of the cavities by means of a loop or a tapered waveguide. Cavities, together with the spaces at the ends of the anode block, form the resonant system that determines the frequency of the generated oscillations. The actual shape of the cavity is not particularly important, and various types are used, as illustrated in Figure. The oscillations associated with the cavities are of such a nature that alternating magnetic flux lines pass through the cavities parallel to the cathode axis, while the alternating electric fields are confined largely to the region where the cavities open into the interaction space. The most important factors determining the resonant frequency of the system are the dimensions and shape of the cavities in a plane perpendicular to the axis of the cathode. Frequency also is affected by other factors such as the end space and the axial length of the anode block, but to a lesser degree.



**Figure : Conventional magnetron structure.**

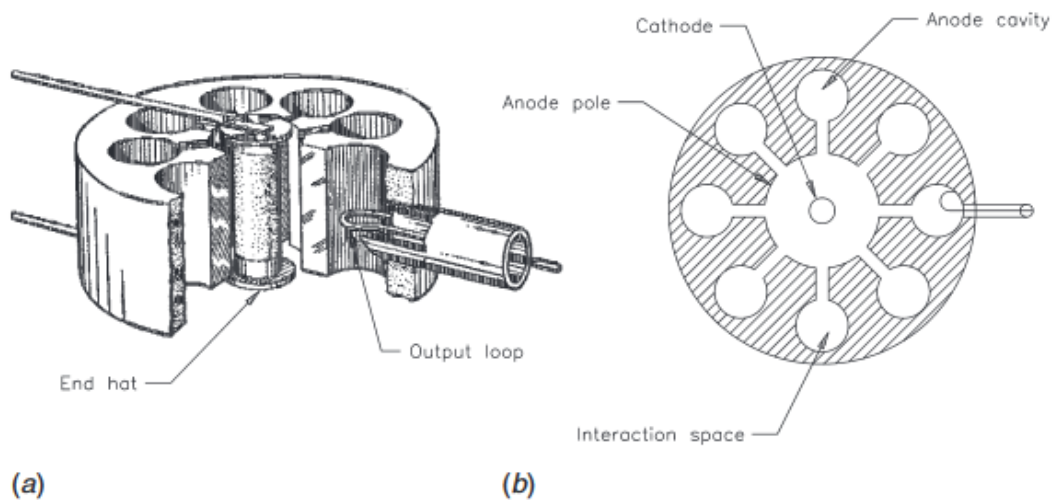

**Figure: Cavity magnetron oscillator: (a) cutaway view, (b) cross section view perpendicular to the axis of the cathode.**

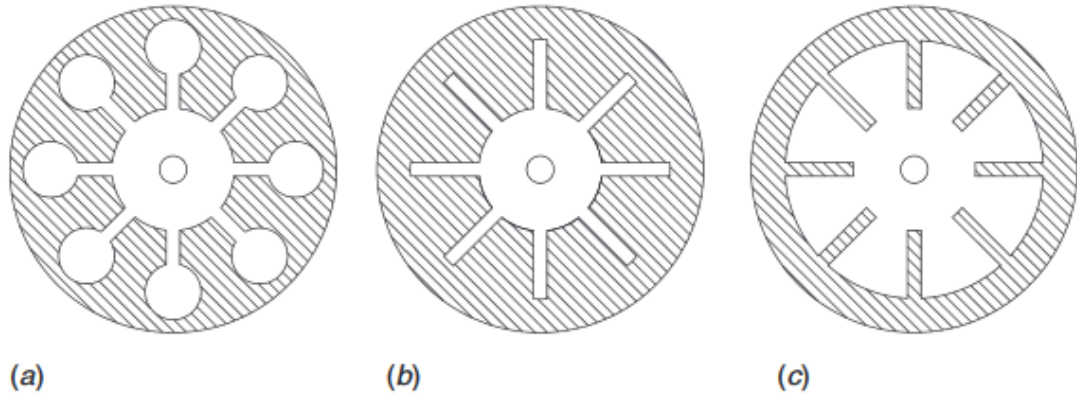

**Figure :** Cavity magnetron oscillator anode: (a) hole-and-slot type, (b) slot type, (c)vane type.

The magnetron requires an external magnetic field with flux lines parallel to the axis of the cathode. This field usually is provided by a permanent-magnet or electromagnet. The cathode is commonly constructed as a cylindrical disk

**DIFFERENCE BETWEEN REFLEX KLYSTRON AND MAGNETRON:**

REFLEX KLYSTRON	MAGNETRON
It is a linear tube in which the magnetic field is applied to focus the electron and electric field is applied to drift the electron.	In magnetron the magnetic field and electric field are perpendicular to each other hence it is called as cross field device.
In klystron the bunching takes places only inside the cavity which is very small ,hence generate low power and low frequency.	In magnetron the interacting or bunching space is extended so the efficiency can be increase.

**APPLICATION:**

- Used as oscillator.
- Used in radar communication.
- Used in missiles.
- Used in microwave oven (in the range of frequency of 2.5Ghz).

**TYPES OF MAGNETRON:**

Magnetron is of 3 types:  
 Negative resistance type.  
 Cyclotron frequency type.  
 Cavity type.

**Construction of cavity magnetron:**

Cavity type magnetron depends upon the interaction of electron with a rotating magnetic field with constant angular velocity.

**FIGURE:**

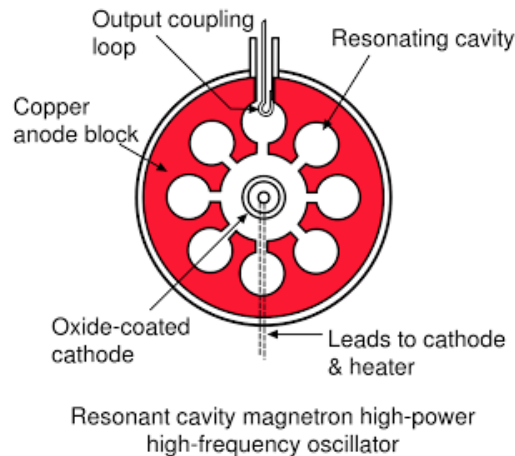

magnetron consists of a cathode which is used to emit electrons and a number of anode cavities a permanent magnet is placed on the backside of cathode. The space between anode cavity and cathode is called interacting space. The electron which are emitted from cathode moves in different path in the interacting space depending upon the strength of electron and magnetic field applied to the magnetron.

**OPERATION:**

**EFFECT OF ELECTRIC FIELD ONLY:**

- In the absence of magnetic field( $B=0$ ) the electron travel straight from the cathode to the anode due to the radial electric field force acting on it(indicated by path A).
- If the magnetic field strength increases slightly it will exert a lateral force which bends the path of the as indicated in path B.

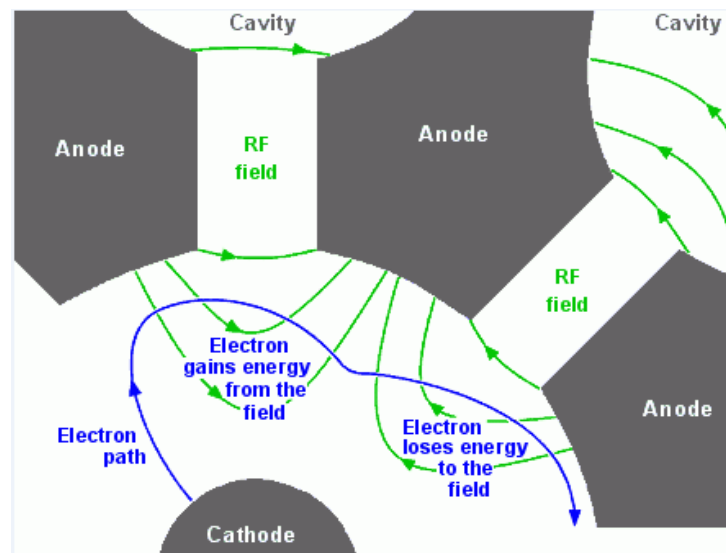

The radius of the path is given as

$$r = mv/eB$$

where  $v$  = velocity of electron

$B$  = magnetic field strength

- If from reaching the anode current become zero (indicated by path D), the strength of magnetic field is made sufficiently high enough, so to prevent the electron
- The magnetic field required to return the electron back to the cathode just touching the surface of anode is called critical magnetic field or cut off magnetic field ( $B_c$ ).
- If  $B > B_c$  the electron experiences a greater rotational force and may return back to the cathode quite faster this results in heating of cathode.

### Effect of magnetic field:

The force experienced by the electron because of magnetic field only.

$$F = q(v \times B)$$

$$= qvB \sin \theta$$

For maximum force  $\theta = 90^\circ$

$$F_{\max} = qvB$$

And hence the electron which are emitted, moved in a right angle with respect to force.

If the magnetic field strength is sufficiently large enough, then the electrons emitted will return back to the cathode with high velocity which may destroy the cathode this effect is called Back heating of cathode.

### $\pi$ MODE OF OSCILLATION:

- The shape consisting of oscillation can maintain if the phase difference between anode cavity is  $n\pi/4$  where n is the mode of operation and the best result can be obtained for  $n=4 \Rightarrow n\pi/4=\pi$  (for  $n=4$  hence it is called  $\pi$  mode operation).
- It is assume that each anode cavity is of  $\lambda/4$  length, hence a voltage antinodes will exist at the opening of anode cavity and the lines of forces present due to the oscillation started by high quality factor device.
- In the above figure the electron followed by path 'b' is so emitted that is not influenced by the electric lines of forces hence it will spend very less time inside the cavity and doesn't contribute to the oscillation so it is called unfavourable electron.
- The electron followed by path a is so emitted that is influence by the electric lines of forces at position 1,2&3 respectively where the velocity increases or decreases, hence more time spend inside the cavity therefore it is called favourable electron.
- Any favourable electron which are emitted earlier or later with respect to reference electron (let a) may be bunch together due to change in velocity by the effect of electric lines of forces. This type of bunching is called phase focusing effect.
- Electrons emitted from the cathode may rotate around itself in a confined area in a shape of spoke (spiral) at a angular velocity and before delivering the energy to the anode cavity. They will rotate until they reach the anode and completely absorbed by them. Hence the magnetron are also called travelling wave magnetron.

### CUT OFF MAGNETIC FIELD (BC):

- Assume a cylindrical magnetron whose inner radius is 'a' and outer radius is 'b' and the magnetic field is as shown in the figure. Under the effect of magnetic field the electrons will rotate in a circular path at any point the force electron will be balance by the centrifugal force.

$$\begin{aligned}\frac{m v^2}{r} &= qvB_z \\ \Rightarrow v &= \frac{qB_z}{m} r \\ \Rightarrow \frac{v}{r} &= \frac{qB_z}{m} \\ \Rightarrow \omega &= \frac{qB_z}{m} \\ \Rightarrow f &= \frac{1}{2\pi} \left( \frac{qB_z}{m} \right)\end{aligned}$$

In cylindrical coordinate system the equation of motion is given as

$$\Rightarrow \frac{1}{\partial} \frac{d}{dt} (v^2 \frac{d\theta}{dt}) = \omega \frac{dr}{dt}$$

$$\Rightarrow \int \frac{d}{dt} (r^2 \frac{d\theta}{dt}) = \omega \int \frac{dr}{dt} \cdot r$$

$$\Rightarrow r^2 \left( \frac{d\theta}{dt} \right) = \frac{\omega r^2}{2} + k$$

Due to electric field only, the electrons move radially from cathode to anode.

$$\Leftrightarrow \frac{1}{2} m v^2 = q V_{dc}$$

$$\Leftrightarrow v = \sqrt{\frac{2qV_{dc}}{m}}$$

$$B_c = \frac{\frac{8mV_{dc}}{b(1-a^2/b^2)}}{b(1-a^2/b^2)}$$

$$V_{dc} = \frac{q}{8m} b^2 (1 - a^2/b^2) B_z^2$$

### GUNN DIODE BASICS:

It has negative resistance property by which gunn diode act as oscillator. To achieve this capacitance and shunt load resistance need to be tuned but not greater than negative resistance. The figure describes **GUNN diode** equivalent circuit. Here active region is about 6-18  $\mu\text{m}$  long. It has negative resistance of about 100 Ohm with parallel capacitance of about 0.6 PF. Gunn diode will have efficiency of only few percentage.

Commercial GUNN diode need supply of about 9V with operating current of 950mA and available from 4GHz to 100GHz frequency band. It is preferably placed in a resonant cavity.

The GUNN diode is basically a TED i.e. Transferred Electron Device capable of oscillating based on different modes. In a unresonant transit time mode, radio frequencies of upto 1-18 GHz with power of upto 2 watt can be achieved. In a resonant limited space charge mode, radio frequencies of upto 100 Ghz with about 100watts of pulsed power can be achieved.

### Gunn Effect:

Gun effect was first observed by GUNN in n\_type GaAs bulk diode. According to GUNN, above some critical voltage corresponding to an electric field of 2000-4000v/cm, the current in



every specimen became a fluctuating function of time. The frequency of oscillation was determined mainly by the specimen and not by the external circuit.

**RIDLEY-WATKINS-HILSUM (RWH) THEORY**

**Differential Negative Resistance**

The fundamental concept of the Ridley-Watkins-Hilsum (RWH) theory is the differential negative resistance developed in a bulk solid-state III-V compound when either a voltage (or electric field) or a current is applied to the terminals of the sample.

There are two modes of negative-resistance devices:

i) Voltage-controlled and

ii) current controlled modes as shown in Fig.

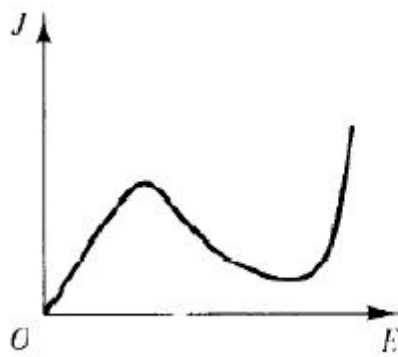

(a) Voltage-controlled mode

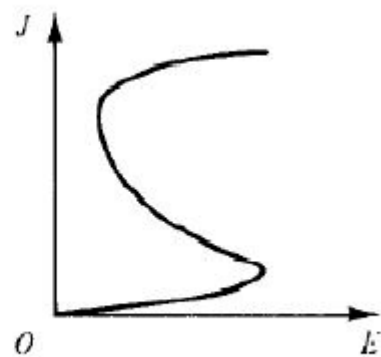

(b) Current-controlled mode

ii) current controlled modes as shown in Fig.

In the voltage-controlled mode the current density can be multivalued, whereas in the current controlled mode the voltage can be multivalued.

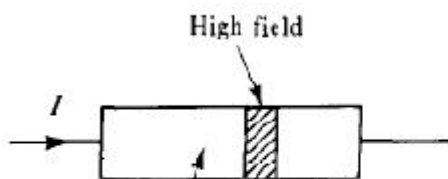

(a) High-field domain

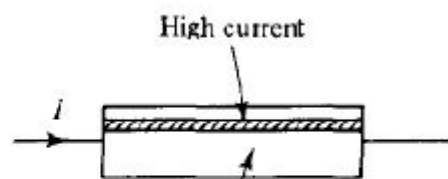

(b) High-current filament

The major effect of the appearance of a differential negative-resistance region in the current density- field curve is to render the sample electrically unstable. As a result, the initially homogeneous sample becomes electrically heterogeneous in an attempt to reach stability.

In the voltage-controlled negative-resistance mode high-field domains are formed, separating two low- field regions. The interfaces separating low and high-field domains lie along equipotentials;

thus they are in planes perpendicular to the current direction as shown in Fig. (a). In the current- controlled negative-resistance mode splitting the sample results in high-current filaments running along the field direction as shown in Fig. (b).

Expressed mathematically,

$$\frac{dI}{dV} = \frac{dJ}{dE} = \text{negative resistance}$$

If an electric field  $E_0$  (or voltage  $V_0$ ) is applied to the sample, for example, the current density is generated. As the applied field (or voltage) is increased to  $E_2$  (or  $V_2$ ), the current density is decreased to  $J_2$ .

When the field (or voltage) is decreased to  $E_1$  (or  $V_1$ ), the current density is increased to  $J_1$  . These phenomena of the voltage controlled negative resistance are shown in Fig. (a). Similarly, for the current controlled mode, the negative-resistance profile is as shown in Fig. (b).

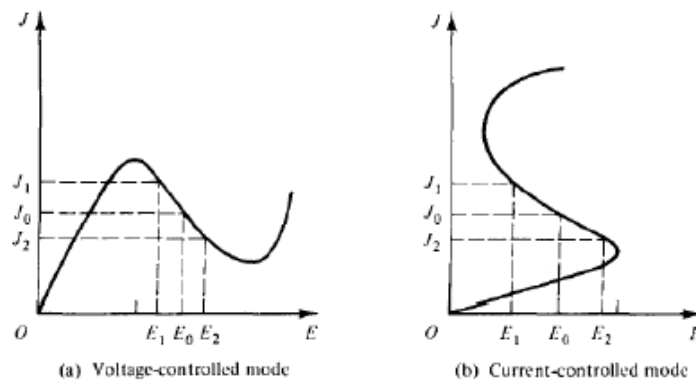

### Two-Valley Model Theory

According to the energy band theory of then-type GaAs, a high-mobility lower valley is separated by an energy of 0.36 eV from a low-mobility upper valley

Valley	Effective Mass $M_e$	Mobility $\mu$	Separation $\Delta E$
Lower	$M_{e\ell} = 0.068$	$\mu_{\ell} = 8000 \text{ cm}^2/\text{V-sec}$	$\Delta E = 0.36 \text{ eV}$
Upper	$M_{eu} = 1.2$	$\mu_u = 180 \text{ cm}^2/\text{V-sec}$	$\Delta E = 0.36 \text{ eV}$

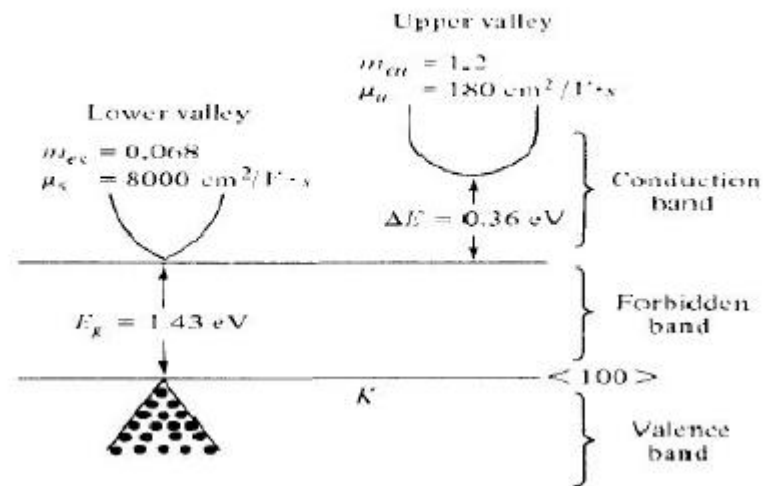

When the applied electric field is lower than the electric field of the lower valley ( $E < E_c$ ), no electrons will transfer to the upper valley as shown in Fig. (a).

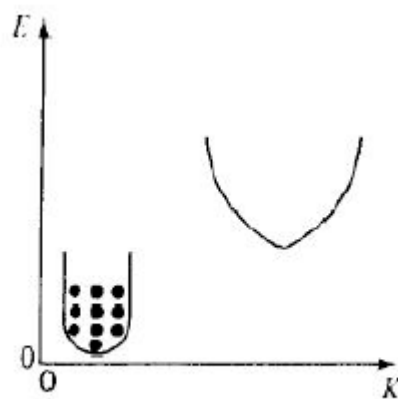

(a)  $E < E_c$

When the applied electric field is higher than that of the lower valley and lower than that of the upper valley ( $E_c < E < E_u$ ), electrons will begin to transfer to the upper valley as shown in Fig.(b).

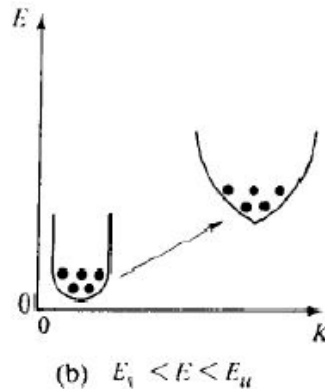

And when the applied electric field is higher than that of the upper valley ( $E_u < E$ ), all electrons will transfer to the upper valley as shown in Fig. (c).

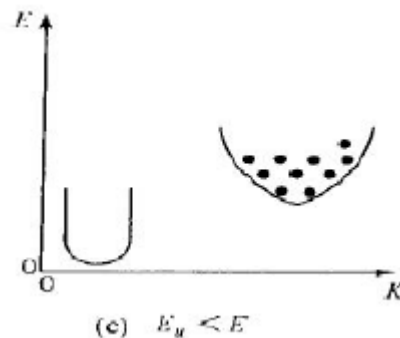

If electron densities in the lower and upper valleys are  $n_l$  and  $n_u$ , the conductivity of the  $n$ -type GaAs is

$$\sigma = e(\mu_l n_l + \mu_u n_u)$$

where  $e$  = the electron charge

$\mu$  = the electron mobility

$n = n_l + n_u$  is the electron density

When a sufficiently high field  $E$  is applied to the specimen, electrons are accelerated and their effective temperature rises above the lattice temperature. Furthermore, the lattice temperature also increases. Thus electron density  $n$  and mobility  $f$ - $L$  are both functions of electric field  $E$ .

### Gunn diode advantages

Following are major advantages of the Gunn diode.

- High frequency stability

- Higher bandwidth and reliability
- Smaller size
- Ruggedness in operation
- low supply voltage
- noise performance similar to klystron
- low cost of manufacturing

#### **Gunn diode disadvantages**

- High turn on voltage
- low efficiency below 10GHz
- Poor bias and temperature stability
- Small tuning range
- Higher spurious FM noise
- higher device operating current and hence more power dissipation
- Lower efficiency and power at millimeter band

#### **GUNN Diode Applications**

- Gunn diode is used as low and medium power oscillators in microwave instruments and receiver circuits
- As pump sources in parametric amplifiers
- Used in police radars and also in CW doppler radars
- Gunn diode oscillators are used to generate power at microwave frequencies for various applications such as automatic door openers, traffic gates, traffic signal controllers etc.

#### **VARACTOR DIODE BASICS:**

This page describes **varactor diode** basics and varactor diode applications. The link to varactor diode calculator, PIN diode, Tunnel diode and GUNN diode basics and applications are also mentioned.

Varactor diode is one of the many microwave semiconductor devices in use today.

They are manufactured with gallium arsenide. Figure depicts symbol of varactor diode and also typical manufacturing package. This diode is used as variable capacitor and as variable reactor in microwave circuits.

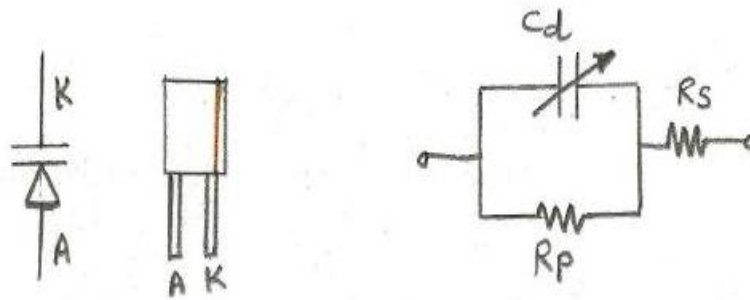

Varactor diode is special type of PN junction diode, in which PN junction capacitance is controlled using reverse bias voltage. When the diode is forward biased, current will flow through the diode. When the diode is reverse biased, charges in the P and N semiconductors are drawn away from the PN junction interface and hence forms the high resistance depletion zone. The equation of the varactor capacitance proportional to the reverse bias voltage is outlined below.

$$C_j = CK / (V_b - V)^m$$

Where,

$C_j$  is the diode capacitance

C is the diode capacitance when the device is unbiased i.e. when V is zero.

V is the applied reverse voltage

$V_b$  is barrier voltage at junction

m is the constant and depends of the material

K is also constant often taken as value of 1

The equivalent circuit of the varactor diode is mentioned in the figure along with the symbol. From the circuit maximum operating frequency of the varactor diode depends on the series resistance and diode capacitance and it is mentioned in the equation below.

$$F = 1 / 2 * \pi * R_s * C_j$$

Quality factor of the varactor diode is mentioned in the equation below.

$Q = F / f$ , where F is the cutoff frequency and f is the operating frequency.

### Varactor Diode Applications

Following are the varactor diode applications:

- It is used in variable resonant tank LC circuit. Here C part is varied using varactor diode.
- AFC(Automatic Frequency Control) where in varactor diode is used to set LO signal.
- Varactor is used as frequency modulator.
- It is used as frequency multiplier in microwave receiver LO.
- It is used as RF phase shifter.

## TUNNEL DIODE BASICS:

Tunnel diode is one of the many microwave semiconductor devices in use today. This page covers Tunnel diode basics and its applications. The tunnel diode operates on tunneling principle which is a majority carrier event. There are few conditions which ensures high tunneling probability.

- thin depletion zone
- heavy doping of semiconductor material

There should be filled and empty energy state for each tunneling carrier.

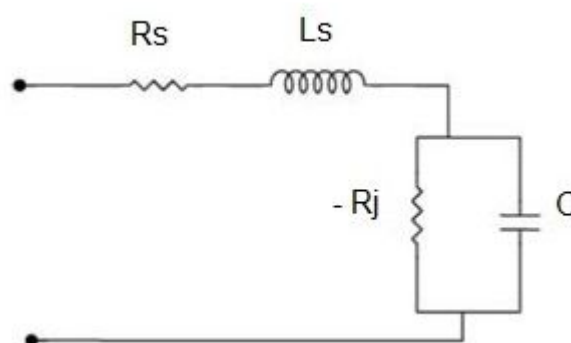

**Fig:1 Tunnel Diode Equivalent Circuit**

From the tunnel diode equivalent circuit it is imperative that tunnel diode oscillates when total reactance is zero and negative resistance balance out the series resistance. There are two type of frequencies equations for which are mentioned below.

$$\text{Resistive Frequency, } F_r \text{ (Hz)} = (1/2 * \pi * R * C_j) * ((R/R_s) - 1)^{0.5}$$

$$\text{Self resonant Frequency } F_s \text{ (Hz)} = (1/2 * \pi) * ((1/L_s C_j) - (1/(R C_j)^2))^{0.5}$$

Where in,

R is the absolute value of negative resistance (Ohms)

$R_s$  is the series resistance (Ohms)

$C_j$  is the junction capacitance (Farads)

$L_s$  is the series inductance (Henrys)

## Tunnel Diode Applications

Tunnel diode is used as an amplifier, as one shot multivibrator and as an oscillator.

## AVALANCE TRANSIT TIME DEVICES:

Avalanche transit-time diode oscillators rely on the effect of voltage breakdown across a reverse biased p-n junction to produce a supply of holes and electrons. Ever since the development of modern semiconductor device theory scientists have speculated on whether it is possible to make a two-terminal negative-resistance device.

The tunnel diode was the first such device to be realized in practice. Its operation depends on the properties of a forward-biased  $p-n$  junction in which both the  $p$  and  $n$  regions are heavily doped. The other two devices are the transferred electron devices and the avalanche transit-time devices.

The transferred electron devices or the Gunn oscillators operate simply by the application of a dc voltage to a bulk semiconductor. There are no  $p-n$  junctions in this device. Its frequency is a function of the load and of the natural frequency of the circuit. The avalanche diode oscillator uses carrier impact ionization and drift in the high-field region of a semiconductor junction to produce a negative resistance at microwave frequencies.

The device was originally proposed in a theoretical paper by Read in which he analyzed the negativoresistance properties of an idealized  $n+p-i-p+$  diode. Two distinct modes of avalanche oscillator have been observed. One is the IMPATT mode, which stands for ***impact ionization avalanche transit-time*** operation. In this mode the typical dc-to-RF conversion efficiency is 5 to 10%, and frequencies are as high as 100 GHz with silicon diodes.

The other mode is the TRAPATT mode, which represents *trapped plasma avalanche triggered transit* operation. Its typical conversion efficiency is from 20 to 60%. Another type of active microwave device is the BARITT (*barrier injected transit-time*) diode. It has long drift regions similar to those of IMPATT diodes. The carriers traversing the drift regions of BARITT, however, are generated by minority carrier injection from forward-biased junctions rather than being extracted from the plasma of an avalanche region. Several different structures have been operated as BARITT diodes, such as  $p-n-p$ ,  $p-n-v-p$ ,  $p-n$ -metal, and metal- $n$ -metal. BARITT diodes have low noise figures of 15 dB, but their bandwidth is relatively narrow with low output power.

### **IMPATT AND TRAPATT DIODE:**

#### ***Physical Structures***

A theoretical Read diode made of  $n^+p-i-p^+$  or  $p^+n-i-n^+$  structure has been analyzed. Its basic physical mechanism is the interaction of the impact ionization avalanche and the transit time of charge carriers. Hence the Read-type diodes are called IMPATT diodes. These diodes exhibit a differential negative resistance by two effects:

- 1) The impact ionization avalanche effect, which causes the carrier current  $i_o(t)$  and the ac voltage to be out of phase by  $90^\circ$
- 2) The transit-time effect, which further delays the external current  $i_e(t)$  relative to the ac voltage by  $90^\circ$

The first IMPATT operation as reported by Johnston et al. in 1965, however, was obtained from a simple  $p-n$  junction. The first real Read-type IMPATT diode was reported by Lee et al., as described previously. From the small-signal theory developed by Gilden it has been confirmed that a negative resistance of the IMPATT diode can be obtained from a junction diode with any doping profile.

Many IMPATT diodes consist of a high doping avalanching region followed by a drift region where the field is low enough that the carriers can traverse through it without avalanching. The



# SIDDHARTH INSTITUTE OF ENGINEERING & TECHNOLOGY:: PUTTUR

---

Read diode is the basic type in the IMPATT diode family. The others are the one-sided abrupt  $p-n$  junction, the linearly graded  $p-n$  junction (or double-drift region), and the  $p-i-n$  diode, all of which are shown in Fig.

The principle of operation of these devices, however, is essentially similar to the mechanism described for the Read diode. Negative Resistance Small-signal analysis of a Read diode results in the following expression for the real part of the diode terminal impedance

$$R = R_i + \frac{2L^2}{v_d \epsilon_s A} \frac{1}{1 - \omega^2/\omega_c^2} \frac{1 - \cos \theta}{\theta}$$

where  $R_i$  = passive resistance of the inactive region  
 $v_d$  = carrier drift velocity  
 $L$  = length of the drift space-charge region  
 $A$  = diode cross section  
 $\epsilon_s$  = semiconductor dielectric permittivity

